

## KGE05 FLOATING THERMOSTAT

### DESCRIPTION

KGE05 floating thermostat is mainly used in central air-conditioning heating and cooling system. It works with TSC series temperature sensor. It provides temperature control for central air-conditioning fan coil cooling / heating motorized valve or other electric actuator by control signal which produced by PID operation between actual tested ambient temperature and setting temperature. When electronic thermostat is power on or turn off, it can output return signal to make the motorized valve or other electric actuator return.



### CHARACTERISTICS

- Auto-return function when power on or turn off.
- Power surge and instant pulse protection.
- Overtime protection function.
- LCD (with backlight) showing ambient temperature and state.
- Percentage display corresponding to DC voltage output value (only suitable for KGE05P, KGE05U). It does not refer to the open extent of the valve.
- Selectable external long-distance temperature sensitive element (NTC thermistor).
- Cool/heat shift: clockwise or anti-clockwise signal output (summer or winter).
- With PC plastic housing, in compliance with UL-94V0 standard.
- With flexible installation and convenient wiring.

### TECHNICAL DATA

PRODUCT NAME	KGE05F		KGE05P		KGE05U	
POWER SUPPLY	AC24V	AC220/230V	AC24V	AC220/230V	AC24V	AC220/230V
OUTPUT	AC24V 1A	AC220/230V 1A	DC 0-10V 20mA	DC 0-10V 20mA	AC24V 1A DC 0-10V 20mA	AC220/230V 1A DC 0-10V 20mA
POWER CONSUMPTION	0.6VA (without load)	10VA (without load)	0.4VA (without load)	10VA (without load)	0.6VA (without load)	10VA (without load)
CONTROL PRECISION	±0.5°C (±1°F)					
CONTROL RANGE	10°C ~ 30°C or 50°F ~ 86°F					
RETURN TIME	≥60s or ≥300s (for optional)					
OVERTIME CUT OFF	Total runtime for valves in the same direction ≥60s (≥300s), turns into overtime protection state.					
SENSITIVE ELEMENT	NTC thermistor 10kΩ (when at 25°C)					
DISPLAY PRECISION	0.2°C / 1°F					
BACKLIGHT CONTROL	Button-press operation (It will automatically go out when stop pressing the button for 5 seconds).					
BACKLIGHT COLOR	Green-G, Blue-B, Yellow-Y (three backlight colors for optional)					
WORKING TEMPERATURE	0 ~ 55 °C					
STORAGE TEMPERATURE	-10 ~ 60 °C					
AMBIENT HUMIDITY	Max. 90% RH no condensation					

## INSTRUCTION

1. **Turn on/Turn off:** When it is power on, the thermostat will self-check, and then make the valve run for 60 seconds (or 300 seconds) continuously towards the closing end. When it finishes operation, the system will enter into **turn off** state. When user presses on/off button (keep for 0.5 seconds and then release), the system will enter into **turn on** state. The LCD backlight will light on for about 5 seconds and then light off automatically. Then it turns into PID temperature control modulating mode. During system operation, when the user presses the on/off button, the LCD will turn off, the valve will run for 60 seconds (or 300 seconds) continuously towards the closing end, and then the system will enter into **turn off** state. Every time when user presses the on/off button, the **turn on/turn off** state will automatically shift.
2. **Cool/heat shift:** During system operation, when user presses the cool/heat shift button, cool/heat state will change over, cool/heat (❄️/☀️) symbol will show on the display.
3. **Temperature setting:** When user presses  $\Delta$  (increase) /  $\nabla$  (decrease) button, LCD display temperature setting will show increase or decrease accordingly. The increase/decrease rate is  $0.2^{\circ}\text{C}$  /  $0.5^{\circ}\text{F}$ . The adjusting range is  $10\sim 30^{\circ}\text{C}$  /  $50\sim 86^{\circ}\text{F}$ . When user stops pressing the button for over 5 seconds, the thermostat will change the setting temperature data in its memory, and then the LCD shows the ambient temperature.
4. **Built-in/external sensor:** When built-in NTC thermistor is used, the jumper J1 should be put to "Int" position (Ex-factory setting position is "Int"). If the external NTC sensor is used, the jumper J1 should be put to "Ext" position.

## WIRING DIAGRAM

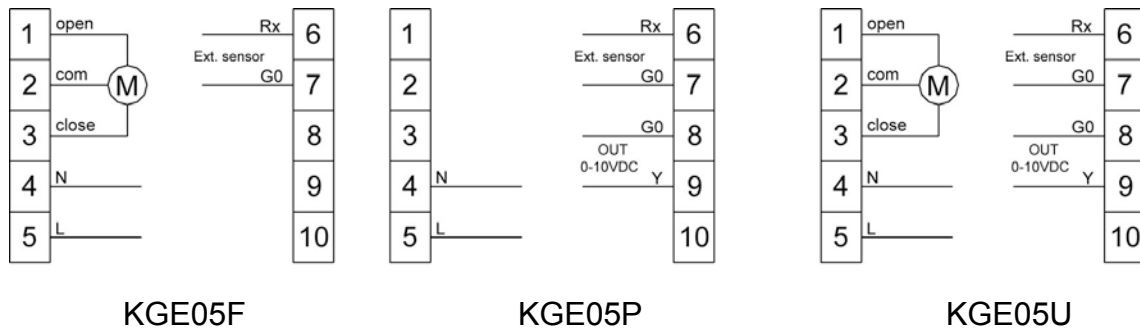

# INSTALLATION DIAGRAM

